

S1400-P39 User manual

SwiftLink series: 1.4GHz
Version: 20240701V3.1

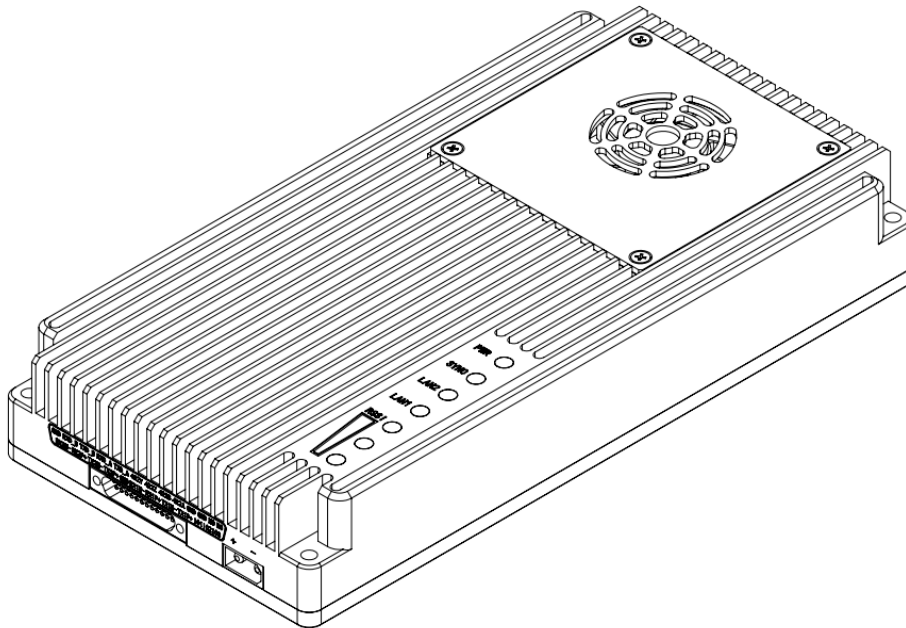

Version history

Date	Version	Modification description
20231219	V1.0	Initial version
20240315	V2.0	Modify the weight dimensions, modify the total data in Table MCS & Sensitivity
20240405	V3.0	Add multiple sets of coexistence switches. Modify the serial-to-network configuration mode. Modify the ID number length and modify the English words of background noise detection. Added the frequency matching function
20240701	V3.1	supports 2 SBUS channels. Optimized antenna selection

Catalogue

Version history	2
1.Product overview	4
2.Product characteristics	4
3.Product index.....	5
4.Product dimension and weight	6
4.1 Dimension diagram.....	6
4.2 Dimension and weight	6
5.Product interface definition	7
5.1 Interface diagram.....	7
5.2 Interface definition	7
6.Product indicator meaning.....	7

1.Product overview

S1400-P39 is a self-developed TDD bidirectional graph integrated wireless transmission device. The product has the functions of real-time interference detection, adaptive frequency selection, adaptive stream, automatic retransmission, and automatic power control, which greatly improves the ability of anti-multipath and anti-interference, and has the characteristics of high reliability, good stability, and low delay.

This product is suitable for firefighting, inspection, monitoring, and other scenarios, and can transmit 100KM under good air-to-ground vision.

2.Product characteristics

- Support long-distance transmission: 4M code flow can be transmitted up to 100km.
- Supports large bandwidth transmission: Up to 16.4Mbps@10MHz.
- Supports automatic repeater transmission: Supports automatic trunk addition.
- Supports multi-interface design: The device has two network ports and four serial ports, supporting RS232/TTL/RS422/SBUS.
- Supports automatic frequency selection: Automatic detection of interference signals, real-time selection of the optimal frequency point.
- Supports automatic retransmission: Automatic retransmission of burst error data improves data reliability.
- Supports adaptive stream: The channel modulation mode is automatically adjusted according to the signal quality in real time.
- Supports automatic power control: Close range automatic adjustment of transmission power, reduce power consumption.
- Supports automatic antenna selection: According to the occlusion situation, the optimal antenna transmission is selected in real time.

- Supports the coexistence of multiple set: Support up to 6 sets of equipment at the same time fixed frequency use.
- Supports the frequency matching function: Software can be used to configure the frequency and hardware key frequency.

3.Product index

System parameter	Technical index
Equipment model	S1400-P39
Working frequency	1350~1470MHz (customizable)
Radio frequency	2T2R
Transmission power	39dBm (8W)
Transmission distance	100KM (Air-to-ground LOS)
Channel bandwidth	10MHz
Modulation mode	QPSK/16QAM
Receiving sensitivity	See Table (MCS & Sensitivity)
Speed	16.4Mbps@16QAM3/4
Communication encryption	AES256
Transmission delay	≤10ms
Radio frequency interface	SMA*2
Equipment interface	XT30PW-M
Equipment interface	100Mbps Ethernet*2
	TTL/RS232*2
	RS422*1
	SBUS*2/TTL*1
Overall power consumption	≤48W@4Mbps(Air uint)
	≤12W@1Mbps(Ground uint)
Dimension(L*W*H)	163*77*25mm
Weight	340g
Working voltage	DC22~30V,Typical value: +24V@2A
Working temperature	-40~+75°C

MCS & Sensitivity (10MHz)			
No.	MCS	Total uplink and downlink throughput (Mbps)	Sensitivity (dBm)
1	QPSK1/3	4.0	-99
2	QPSK1/2	5.8	-98
3	QPSK2/3	7.1	-97
4	QPSK3/4	8.2	-96
5	16QAM1/3	8.0	-96
6	16QAM1/2	11.6	-95
7	16QAM2/3	14.3	-93
8	16QAM3/4	16.4	-91

4.Product dimension and weight

4.1 Dimension diagram

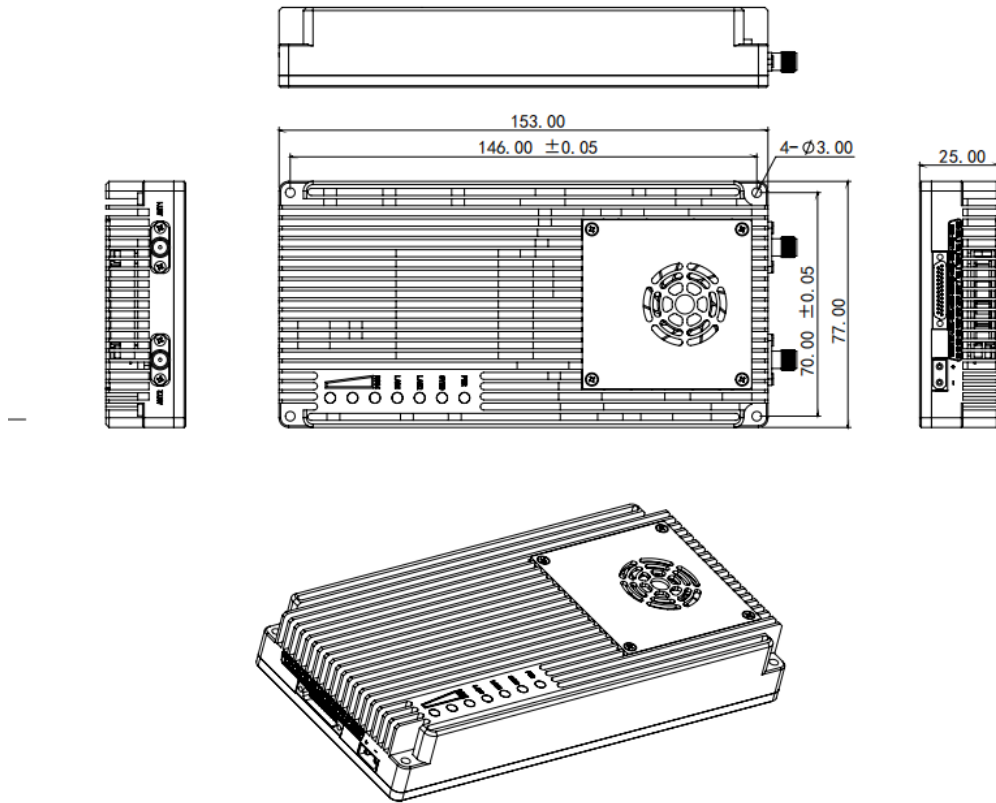

4.2 Dimension and weight

- ◆ Dimension (L*W*H): 163mm*77mm*25mm(including SMA 10mm)
- ◆ Weight : 340g

5.Product interface definition

5.1 Interface diagram

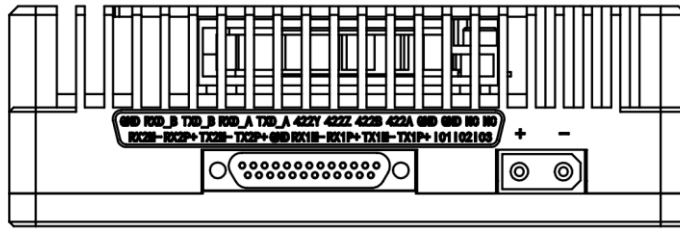

The interface of the S1400-P39 device includes the XT30PW-M power interface and J30J-25pin data interface. The interface has RS232/TTL*2, RS422*1, SBUS*2 or TTL*1 and 100 Mbit/s Ethernet*2.

5.2 Interface definition

Power interface: XT30PW-M. Power supply range: DC22-30V Typical value:24V@2A

Linear order	Pin name	Interface definition	Interface description	Signal direction
1,2,3,4	GND	Ground	Ground	
5	422A	Serial port 3 RS-422	Receiving data RX+	I
6	422B		Receiving data RX-	I
7	422Z		Transmitting data TX-	O
8	422Y		Transmitting data TX+	O
9	TXD_A	Serial port 1 RS232/TTL	Transmitting data TX	O
10	RXD_A		Receiving data RX	I
11	TXD_B	Serial port 2 RS232/TTL	Transmitting data TX	O
12	RXD_B		Receiving data RX	I
13	GND		Serial port 2 ground	O
14	SBUS /TTL TX	Serial port 4 SBUS*2/TTL*1	SBUS only Output (Air)	O
15	SBUS /TTL RX	(Note 2,3)	SBUS only Input (Ground)	I
16	TTL GND		TTL ground	O
17	TX1P+	Network port 1	Transmitting data TX+	O
18	TX1M-		Transmitting data TX-	O
19	RX1P+		Receiving data RX+	I
20	RX1M-		Receiving data RX-	I
21	GND	Ground	Serial port 1 ground	O
22	TX2P+	Network port 2	Transmitting data TX+	O
23	TX2M-		Transmitting data TX-	O
24	RX2P+		Receiving data RX+	I
25	RX2M-		Receiving data RX-	I

Note1: Signal direction I indicates radio input and direction O indicates radio output.

Note2: SBUS 14 and 15pin are input on the ground side, and SBUS14 and 15pin are output on the air side

Note3: If you need to use two SBUS, you need to configure 14-pin > 14-pin for the air server SBUS mapping. 15pin->15pin.

6.Product indicator meaning

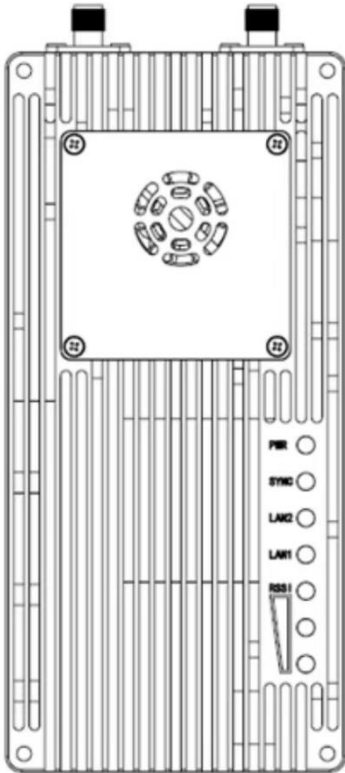

Power light PWR (green)

When the PWR light is on, the device is powered on.

SYNC (green)

Out of sync state, light flashing.

After synchronization, the light is steady on.

Network port light : LAN1, LAN2 (green)

The network port light blinks when data is being sent or received.

Receiving signal energy light(RSSI 3 green lights)

The greater the number of energy lights, the greater the signal reception strength.

The RSSI light represents the strength of the received signal	
Number of RSSI energy lights on	Received energy dBm
3 RSSI lights on	about -50dBm
2 RSSI lights on	about -80dBm
1 RSSI light on	about -95dBm

Module type	Mode	S1400-P39 light status			
		PWR	SYNC	LAN 1 LAN 2	RSSI 123
master	Un-sync	Powered on	Flashing	Data sending and receiving, flashing	Off
master	Sync	Powered on	Steady on	Data sending and receiving, flashing	Proportional to the strength of the received signal
slave	Un-sync	Powered on	Flashing	Data sending and receiving, flashing	Searching
slave	Sync	Powered on	Steady on	Data sending and receiving, flashing	Proportional to the strength of the received signal

When the master and slave devices are not synchronized, the PWR indicator of the master and slave devices is steady on, the SYNC indicator is blinking, and the RSSI indicator of the master device is off. The RSSI of the slave device will always be in the search state. After the master/slave synchronization, the SYNC indicator of the master/slave is steady on. The master-slave RSSI lamp displays the received signal energy intensity. When the network port is sending or receiving data, the master and slave devices correspond to LAN1, and the LAN2 indicator blinks.